



Xtra Slim Laser Video Wall

60" Full HD Laser Video Wall

- Rich picture quality with Full HD Resolution for superb image quality
- Ultra High Brightness to give the most vivid colors
- High lumens efficiency for reducing operating costs
- Browser/Server based architecture for quick monitoring
- Slimmest Laser Cube saves real state



60" Full HD Laser Video Wall

Delta's Laser Video wall is a rear projection, Laser based Full HD Video wall that offers environment friendly Laser illumination, ultra high brightness and true cube redundancy. Industry's first ultra-bright Laser based DLP® video wall improves energy savings of up to 33%.

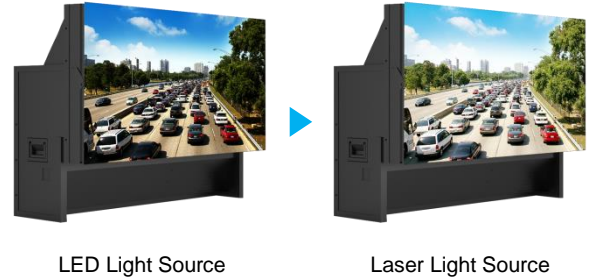
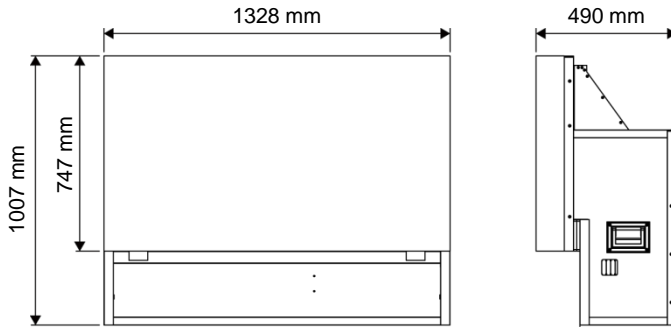

Specifications

Model	DVS-608RS / DVS-608FS					
Description	Laser Light Source Full HD Cube					
Individual Cube Size	60" Diagonal					
Image Size	1328 x 747 mm					
Display Technology	DLP, single chip					
Native Resolution	1920 x 1080 pixels					
Aspect Ratio	16:9					
Screen to Screen Gap	Rear Access : 0.2mm, Front Access : 1.0 mm					
Light Source	Laser					
Brightness	Typ. 2400 lumens ^{*1}					
Brightness Uniformity	Up to 98% ^{*2}					
Contrast Ratio	Typ. 1800:1					
Colors	16.7 million					
Color Temperature Range	3200K to 9300K, Custom					
Standard Inputs	1x Digital DVI-I, 1x Digital HDMI, 1x Analog D-sub 15pin, 1x Analog 5BNC (RGBHV or YPbPr)					
Standard Outputs	1x Digital DVI-D					
Optional Board	I ^{*3}	Inputs	1x Digital DVI-D, 1x HDMI, 1x Display port, 1x Analog 5BNC (RGBHV or YPbPr), 1x Analog S-video			
	II ^{*3}	Inputs	1x Digital DVI-D, 1x 3G-SDI, 1x Display port, 1x Analog 5BNC (RGBHV or YPbPr), 1x Analog S-video			
		Output	1x 3G-SDI			
III ^{*3}	Inputs	1x Digital DVI-D, 1x HD-baseT, 1x Display port, 1x Analog 5BNC (RGBHV or YPbPr), 1x Analog S-video				
Control Options	RS-232 / RS 422, IP, IR					
Screen Brightness	Screen Type	Bright mode	Normal mode	ECO mode	Screen Viewing Angle (1/2 Gain)	
	CSI	800 cd/m ²	600 cd/m ²	400 cd/m ²	H: 36°	V: 34°
	XMD-AG	870 cd/m ²	650 cd/m ²	440 cd/m ²	H: 31°	V: 17°
Light source Average Life	60,000 hours	80,000 hours	100,000 hours			
Power Consumption	320 w	250 w	160 w			
Input Voltage	AC 90-240 V @ 50/60 hz					
Power Supply	Dual Power supply available as an option					
Dimension & Weight	(WxHxD) : 1328 x 1007 x 490 mm, Net Weight : Rear = 107Kg, Front = 113Kg					
Operating Temperature	5°C ~ 40°C (41°F ~ 104°F), Operating Altitude : <= 4000M					
Non-Operating Temperature	-20°C ~ 60°C (-4°F ~ 140°F)					
Operating / Storage Humidity	10% ~ 90%, non-condensing					

Note: *1. Bright mode Engine Brightness, *2. Through electronical compensation, *3 Only one of the optional boards can be used with standard input / output board.
 ※ All specifications are subject to change without prior notice. Ver:07.2017